

## L6H5

### Load Cell L6H5



#### Products specification

- ◆ L6H5 load cells are available in the capacities 4kg to 20kg.
- ◆ Aluminum construction with parallel beam.
- ◆ Silicon adhesive sealed, surface anodized and anti-corrosion.
- ◆ Integral structure and easy installation.
- ◆ Suitable for electroic balance and other electronic weighing devices.

#### Features

- ◆ Capacity: 4kg to 20kg .
- ◆ High accuracy.
- ◆ Max. platform size: 200x200mm.

#### Specifications

Capacity	(kg)	4/5/8/10/15/20
Accuracy		C3D
Maximum number of verification intervals	n max	2500
Minimum load cell verification interval	v min	Emax/5000
Combined error	(%FS)	≤±0.030
Creep	(%FS/30min)	≤±0.020
Temperature effect on sensitivity	(%FS/10°C)	≤±0.021
Temperature effect on zero	(%FS/10°C)	≤±0.028
Output sensitivity	(mv/v)	2.0±0.2
Input resistance	(Ω)	406±6
Output resistance	(Ω)	350±3
Insulation resistance	(MΩ)	≥5000(50VDC)
Zero balance	(%FS)	2
Temperature, compensated	(°C)	-10~+40
Temperature, operating	(°C)	-35~+65
Excitation, Recommended	(V)	5~12(DC)
Excitation, Max	(V)	18(DC)
Safe overload	(%FS)	150
Ultimate overload	(%FS)	300
Corner correction		0.02% load value/100mm

#### Outline Dimension mm(inch)

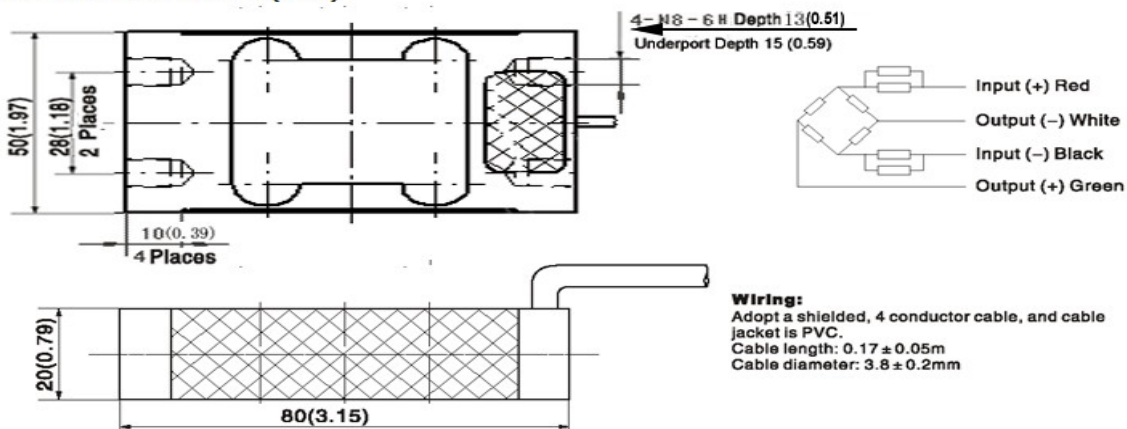

HANGZHOU GONGHENG WEIGHING EQUIPMENT CO.,LTD

[www.hzgh-scales.com](http://www.hzgh-scales.com)

[hzghscale@yahoo.com](mailto:hzghscale@yahoo.com)