

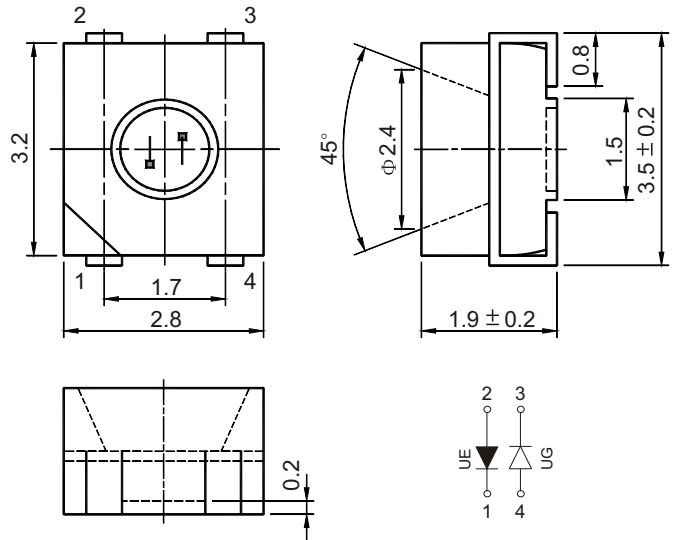

● Features:

1. Chip material: AlGaInP/GaAs
2. Emitting color: Ultra Orange/ Ultra Green
3. Lens Appearance: Water Clear
4. Long life-solid state reliability
5. Compatible with automatic placement equipment
6. Compatible with reflow solder process
7. RoHS compliant

● Package dimensions



Notes:

1. All dimensions are in millimeters (inches).
2. Tolerance is ±0.25mm (0.01") unless otherwise specified.
3. Specifications are subject to change without notice.



● Absolute maximum ratings (Ta=25°C)

Characteristic	Test Condition	Symbol	UE	UG	Units
Pulse Forward Current	1/10 duty cycle 0.1ms Pulse width	I _{FP}	60	60	mA
DC Forward Current		I _F	20	20	mA
Reverse Current	V _R =5V	I _R	10	10	μA
Power Dissipation		P _D	65	80	mW
Operating Temperature		T _{OPR}	-40 to +80		°C
Storage Temperature		T _{STG}	-40 to +85		°C
Lead Soldering Temperature	1.60mm from body maximum 3 seconds	T _{SOL}	260		°C



● Electrical And Optical Characteristics(Ta=25°C)

Parameter	Test Condition	Symbol	Colors	Typ.	Max.	Units
Forward Voltage	IF=20mA	V _F	UE	2.00	2.50	V
Reverse Current	V _R =5V	I _R		---	10	μA
Peak Wavelength	IF=20mA	λ _P		632	---	nm
Dominant Wavelength	IF=20mA	λ _D		624	---	nm
Spectral Line Half-width	IF=20mA	Δλ		20	---	nm
Luminous Intensity	IF=20mA	I _V		180	---	mcd
Forward Voltage	IF=20mA	V _F	UG	2.10	2.50	V
Reverse Current	V _R =5V	I _R		---	10	μA
Peak Wavelength	IF=20mA	λ _P		574	---	nm
Dominant Wavelength	IF=20mA	λ _D		571	---	nm
Spectral Line Half-width	IF=20mA	Δλ		15	---	nm
Luminous Intensity	IF=20mA	I _V		120	---	mcd
Viewing Angle	IF=20mA	2θ½	UEUG	120	---	deg.

● Typical electro-optical characteristics curves

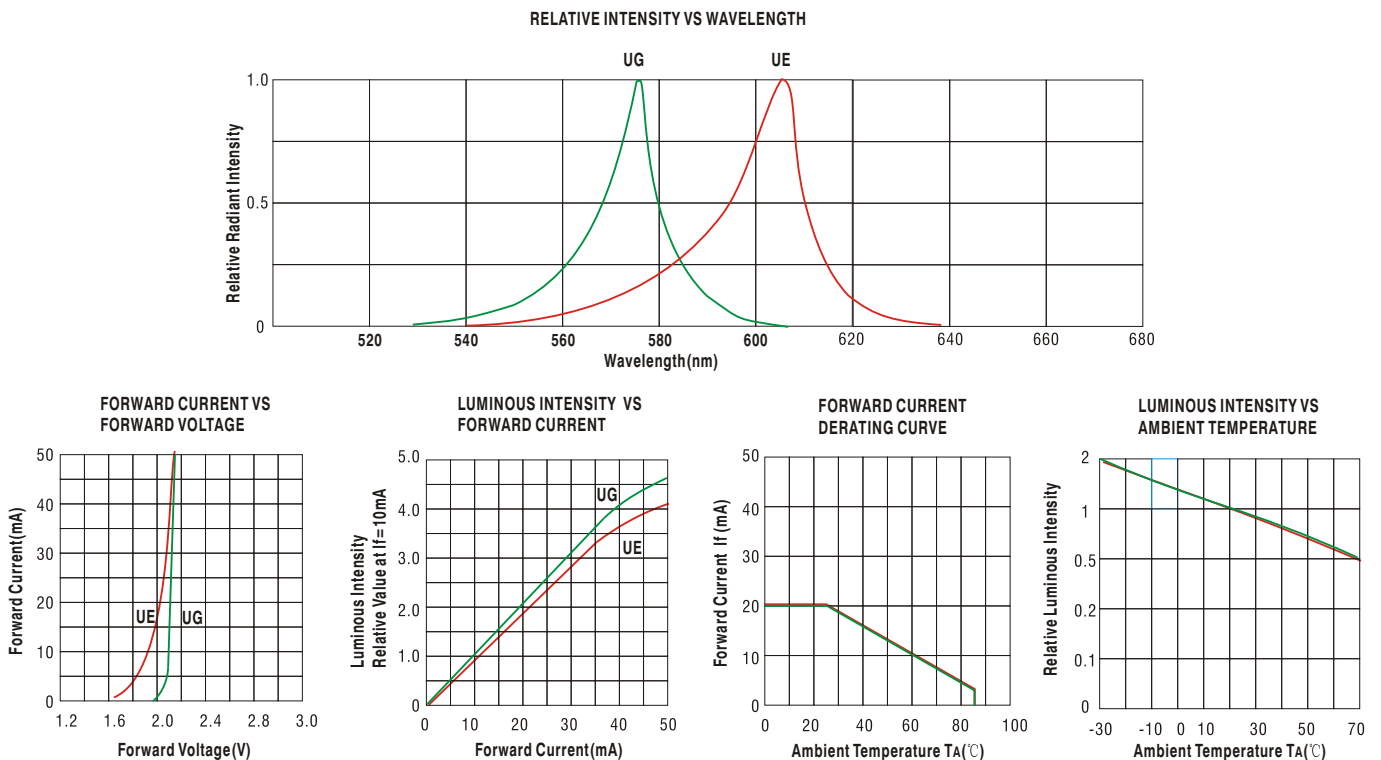



● Soldering Pad Dimensions:

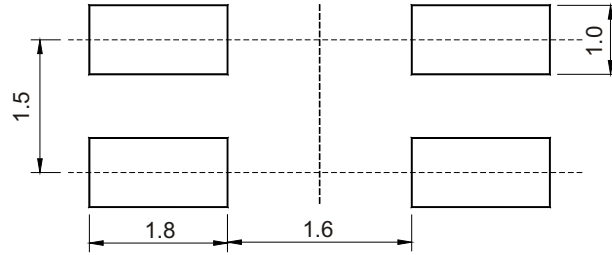

● Soldering Conditions:

1.Reflow soldering profile

Lead-free solder

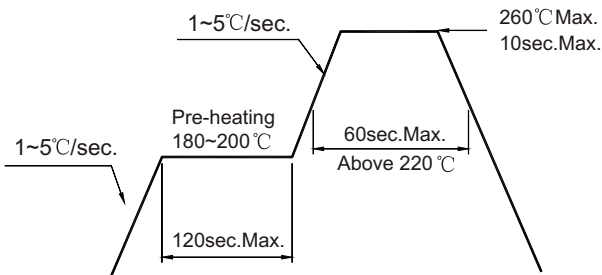

2.Soldering Iron

Power dissipation of iron should be smaller than 25W, and temperature should be controllable. The work must be finished within 3sec. under 300°C only once.

Do not stress its resin while soldering.

After soldering, do not warp the circuit board.

● Package Tape Specifications:(1000~2000pcs/Reel)

