



26.00mm X 7.50mm Single Color Light Bar

Features:

- *High segment intensity
- *Wide viewing angle
- *Range of colors
- *Gray face White segment
- *RoHS compliant

Available option:

- *Alternative face color
- *Cropped terminal pins
- *Available emitting color
- *Low current version

Electro/Optical Characteristics If=20mA Ta=25°C

Part Number	Emitting Color	Peak Wavelength	Forward Voltage V _F		Luminous Intensity I _v	
			Typ.	Max.	Min.	Typ.
NFA-R2608ZUHR-01	AlGaInP/GaAs Ultra Red	640	8.00	10.00	160.00	240.00
NFA-R2608ZUE-01	AlGaInP/GaAs Ultra Orange	632	8.00	10.00	160.00	240.00
NFA-R2608ZYO-01	AlGaInP/GaAs Ultra Amber	605	8.00	10.00	160.00	240.00
NFA-R2608ZUY-01	AlGaInP/GaAs Ultra Yellow	590	8.00	10.00	160.00	240.00
NFA-R2608ZUG-01	AlGaInP/GaAs Ultra Green	574	8.00	10.00	100.00	160.00
NFA-R2608ZPG-01	InGaN/SiC Pure Green	525	13.20	15.20	600.00	800.00
NFA-R2608ZUB-01	InGaN/SiC Ultra Blue	470	13.20	15.20	160.00	400.00
NFA-R2608ZUW-01	InGaN/SiC Ultra White	X-0.31/Y-0.31	13.20	15.20	800.00	2000.00
Units		nm	V		mcd	

Maximum Ratings Ta=25°C (Derate above 25°C)

Characteristic	Test Condition	Symbol	UHR	UE	YO	UY	UG	PG	UB	UW	Units
Pulse Forward Current Per Seg.	1/10 duty cycle 0.1ms Pulse width	I _{FP}	100	100	100	100	100	100	100	100	mA
DC Forward Current Per Seg.		I _F	30	30	30	30	30	30	30	30	mA
Reverse Current Per Seg.	V _R =10V	I _R	10	10	10	10	10	10	10	10	μA
Power Dissipation		P _D	65*4	65*4	65*4	65*4	75*4	110*4	120*4	120*4	mW
Operating Temperature		T _{OPR}	-40 to +80								°C
Storage Temperature		T _{TSG}	-40 to +85								°C
Lead soldering temperature	1.60mm from body maximum 3 seconds		260								°C

Checked

Chen N.H.

Approved

Jason Chen

Date

Feb/08/2007

PAGE 1 / 2



26.00mm X 7.50mm Single Color Light Bar

PACKAGE DIMENSION

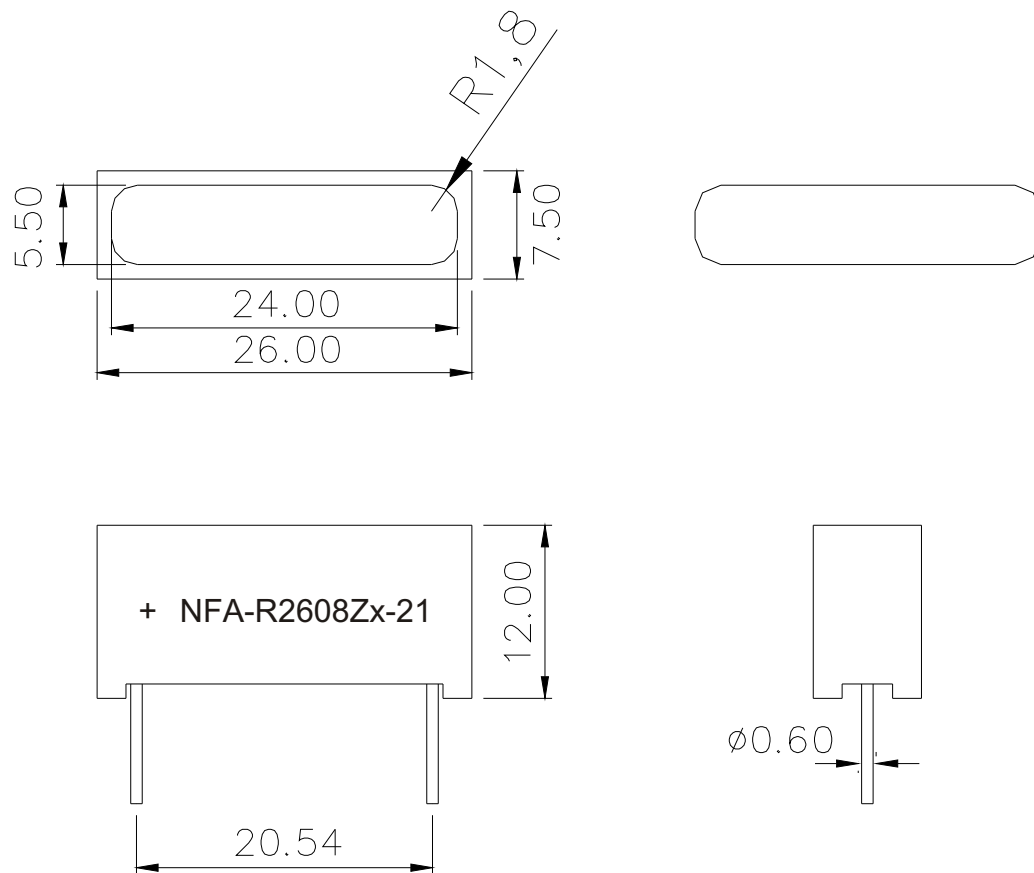

INTERNAL CIRCUIT DIAGRAM

NFA-R2608Zx

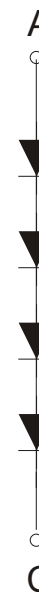

Tolerance $\pm 0.25\text{mm}$ unless stated

Checked

Chen N.H.

Approved

Jason Chen

Date

Feb/08/2007

PAGE 2 / 2