

1.2M 跌落测试报告

1.2M Drop Test Report

| | |
|------------------------------------|---|
| Client 委托方 | Semilink Inc. |
| Add. of Client 委托方地址 | #417 Doosan Venture Digm 126-1, Pyeongchon-dong, Dongan-gu, Anyang-si, Gyunggi-do, Korea |
| Samples Description 样品名称 | Polymer lithium ion cell 聚合物锂离子电芯 |
| Model/Type 型号规格 | 502530 |
| Testing Laboratory 测试机构 | Shenzhen TCT Testing Technology Co., Ltd. 深圳市通测检测技术有限公司 1F, Building 1, Yibaolai Industrial Park, Qiaotou Village, Fuyong Town, Baoan District, Shenzhen, Guangdong, China 中国广东省深圳市宝安区福永桥头亿宝来工业城 1 栋 1 楼 |
| Report No. 报告编号 | TCT160407B016-1 |
| Issued Date 发行日期 | Apr. 19, 2016 |
| Test Conclusion 测试结论: | Shown in the Conclusion of test report. 见检测报告结论页. |

Tested by 主检人: 张丽裙 Sunny Zhang

Approved by 批准人: 李明波 Will Do.

Inspected by 审核人: 张丽裙 Liz Zhang

Seal of TCT 报告单位 (盖章): 

Date of Issue 签发日期: 2016.04.19

I、SAMPLE DESCRIPTION 样品描述

| | | | | | |
|---|--|-------------------------------|--|--|--------------------|
| Product Name 产品名称 | Polymer lithium ion cell 聚合物锂离子电芯 | | Sample Model 样品型号 | 502530 | |
| Manufacturer 制造商 | Dongguan Liliang Electronics Co., LTD 东莞市立量电子有限公司 | | | | |
| Address 地址 | No. B, Science park zhaoxuan, Road No.3hong, Southern District, Dongguan 东莞市南城区宏三路兆炫科技园 B 栋 | | | | |
| Trade Mark 商标 | ---- | Shape 形状 | Prismatic 棱形 | Packaging dimensions 包装尺寸 (L×W×T) | (30.0×24.0×18.0)cm |
| Nominal Voltage 标称电压 | 3.7V | Rated Capacity 额定容量 | 300mAh 1.11Wh | Battery Number 电池数量 | 690/PCS |
| Gross weight per package 每包装件毛重 | 5.3Kg | | Net weight of batteries per package 每包装件锂离子电池的净重 | 4.3kg/packing | |
| Receiving Date 接收日期 | 2016-04-12 | | Completing Date 完成日期 | 2016-04-19 | |

II、STANDARD 标准

Section IB of Packing Instructions 965 of 57th DGR Manual of IATA.
IATA《危险品规则》(57版)包装说明965第IB章节。

III、TEST ITEM 测试项目

- 1). Drop test 跌落测试
- 2). Packing weight test 包装重量测试

IV、TEST METHOD 测试方法

The package of batteries is dropped from 1.2m, 5times per package. The test floor is concrete floor, each package is capable of withstanding a 1.2 meter drop test in any orientation without damage to cell or batteries contained therein. Without shifting of the contents so as to allow battery to battery (or cell to cell) contact and without release of contents.

电池包装件(或含有电池的包装件)从 1.2 米高度进行跌落,每个包装件 5 次.测试底板为混凝土底板,每一个包装件应能承受在任一方位的 1.2 米跌落测试,并且没有电芯或电池损坏.没有位移导致电池或电芯相互接触,并没有内部物品从箱体漏出.

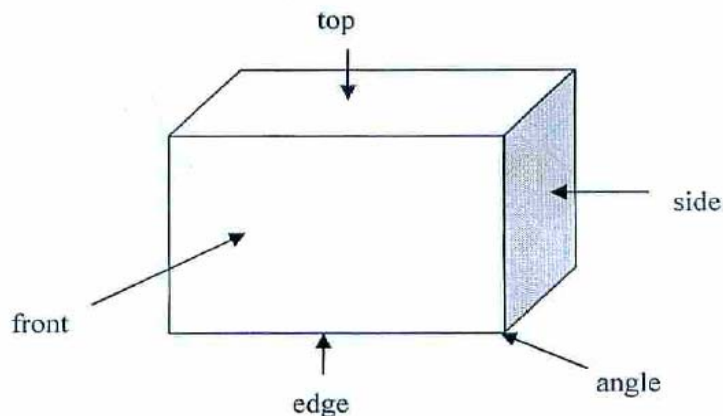

V、TEST APPARATUS 测试仪器

| Serial No. 设备编号 | Name of Equipment 设备名称 | Model 型号 | Calibration Date /Due Date 校准日期/到期日 |
|--------------------|--------------------------------------|-------------|---|
| TC-105 | Single-blade drop tester 单翼跌落测试仪器 | GX-6050-A | 2015. 08. 25 |
| | | | 2016. 08. 24 |
| TC-045 | Electronic scale 电子秤 | TCM-150 | 2015. 08. 25 |
| | | | 2016. 08. 24 |

VI、TEST RESULT 测试结果

1) Drop test 跌落测试

| Drop position 跌落位置 | Test status 测试情况 | Conclusion 结论 |
|-----------------------|------------------------------------|------------------|
| Front 前面 | Without damage packaging 包装没有损坏 | Pass 合格 |
| Bottom 底部 | Without damage packaging 包装没有损坏 | Pass 合格 |
| Angle 角 | Without damage packaging 包装没有损坏 | Pass 合格 |
| Side 侧面 | Without damage packaging 包装没有损坏 | Pass 合格 |
| Top 顶部 | Without damage packaging 包装没有损坏 | Pass 合格 |

2) Packing weight test 包装重量测试

| No. 编号 | Test item 测试项目 | Weight 重量 (kg) | Remark 备注 |
|-----------|-------------------------------|-------------------|--------------|
| 1 | Packing weight test 包装重量测试 | 5.3 | --- |

Photos 照片

Samples 样品:

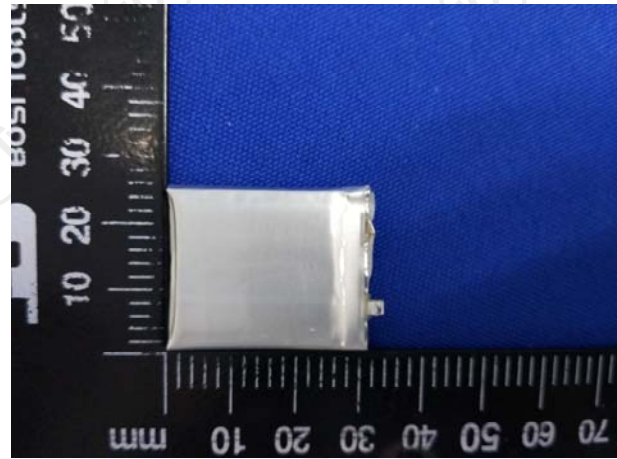

Package 包装:



Package 包装:



注意事项

Important Notice

1. The test report is invalid without the official stamp of TCT and Paging seal of TCT.
本报告书无 TCT 盖章、骑缝章无效。
2. Nobody is allowed to photocopy or partly photocopy this test report without written permission of TCT.
未经 TCT 书面同意，不得部分地复制本报告书。
3. The test report is invalid without the signatures of Ratifier, Reviewer and Testing engineer.
本报告书无批准人、审核人、及主检人签名无效。
4. The report is invalid when anything of following happens – illegal transfer, reproduce, embezzlement, imposture, modification or tampering in any media form.
私自转让、复制、盗用、冒用、涂改、或以任何媒体形式篡改的报告书无效。
5. Objections to the test report must be submitted to TCT within 15 days.
对报告书若有异议，应于收到报告之日起 15 天内向本公司提出。
6. The test report is valid for the tested samples only.
本报告仅对测试样品有效。
7. The Chinese contents in this report are only for reference.
本报告中的中文内容仅供参考。

*******End of Report 报告结束*******